

## Half Butterfly Driver Cable

- Designed for Thorlabs' Half Butterfly Gain Chips (See Pages 1386 - 1387)
- Use with Custom/Developmental External Cavity Lasers
- Offers DB9 Connections for Thorlabs' LD and TEC Controllers (See Pages 1435 - 1480)

Fabry-Perot Gain Chip Pin Configuration

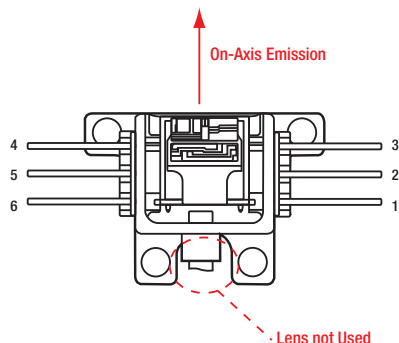

Fiber-Coupled SAF Gain Pin Configuration

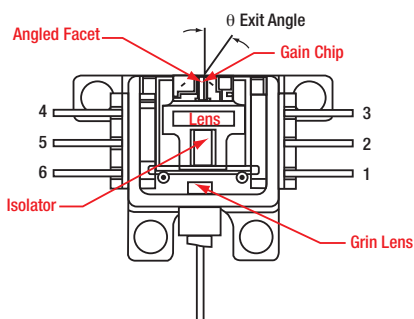

Half Butterfly Pin Configuration

PIN	CONNECTOR
1	TEC+
2	Thermistor
3	Thermistor
4	Device Anode
5	Device Cathode
6	TEC-

The TLK-C03 interfaces a half butterfly gain chip to Thorlabs' laser diode drivers and TEC controllers. This easy-to-use device has numbered sockets for error-free connection to Thorlabs' half butterfly gain chips. Common applications include testing gain chips before integration into a complete system. Thorlabs' TEC controllers mate to the unit's male DB9 connector, while the LD drivers attach to the female DB9 connector.



ITEM #	\$	£	€	RMB	DESCRIPTION
TLK-C03	\$ 128.00	£ 92.16	€ 111,36	¥ 1,020.16	Half Butterfly Package Breakout Cable Set

NEW

Have you seen our...

## Tunable Laser Kits

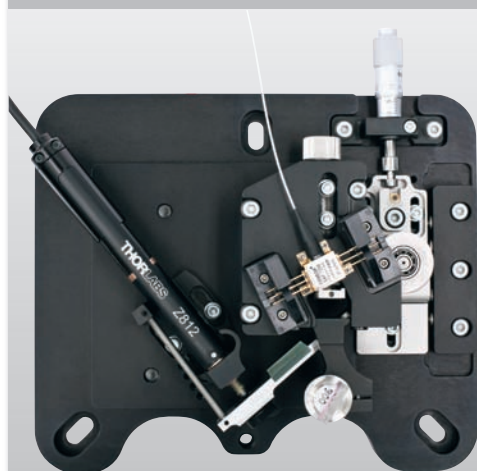

- ◆ Modular Design with User-Customizable Optics, Gain Chip, Tuning, etc.
- ◆ Linewidths Less than 130 kHz
- ◆ 10 dB Tuning Ranges up to 170 nm
- ◆ Laser Components Stocked to Maximize Configurability

The Tunable Laser Kit line is a rapidly growing family of tunable lasers that give users full access to the laser cavity. With unsurpassed user configurability, Tunable Laser Kits are an excellent choice for customers that need to tailor a laser to their application.

See pages 1286 - 1299